

# OPERATOR'S MANUAL

## FPD 10 WATT POWER SUPPLIES

Flat Pack Single Output DC to DC Converter  
10 Watts, Single Output  
36 to 72 Vdc Input

KEPCO INC.  
An ISO 9001 Company.

### MODEL FPD 10 WATT POWER SUPPLY

ORDER NO.

REV. NO.

#### IMPORTANT NOTES:

- 1) This manual is valid for the following Model and associated serial numbers:

MODEL	SERIAL NO.	REV. NO.
-------	------------	----------

- 2) A Change Page may be included at the end of the manual. All applicable changes and revision number changes are documented with reference to the equipment serial numbers. Before using this Operator's Manual, check your equipment serial number to identify your model. If in doubt, contact your nearest Kepco Representative, or the Kepco Documentation Office in New York, (718) 461-7000, requesting the correct revision for your particular model and serial number.
- 3) The contents of this manual are protected by copyright. Reproduction of any part can be made only with the specific written permission of Kepco, Inc.

Data subject to change without notice.

©2000, KEPCO, INC  
P/N 243-0804



KEPCO, INC. • 131-38 SANFORD AVENUE • FLUSHING, NY. 11352 U.S.A. • TEL (718) 461-7000 • FAX (718) 767-1102  
email: [hq@kepcopower.com](mailto:hq@kepcopower.com) • World Wide Web: <http://www.kepcopower.com>

# FLAT PACK

## Single Output

### DC to DC Converters

#### I INTRODUCTION:

**SCOPE OF MANUAL:** This instruction brief contains information for the installation and operation of the Kepco FPD 10 Watt DC to DC Converter Series of switching power supplies. For further operating and service information for the FPD 10 Watt DC to DC Converter Series contact your Kepco Representative directly, or write to Kepco, Inc., 131-38 Sanford Avenue, Flushing, New York 11352 U.S.A.

**DESCRIPTION:** The Kepco FPD 10 Watt DC to DC Converter Series consists of three switching power supplies, having a nominal 36-72 Vdc input and different DC output voltages, rated as listed in Section II. FPD 10 Watt Converter switching power supplies have similar electrical specifications, except for the output ratings. They are low-dissipative stabilizers, using pulse-width modulation to control the output. The units feature input/output isolation and remote ON/OFF. Remote ON/OFF is accomplished by an isolated TTL level signal that may use either mechanical or solid state closure. All models are guaranteed for one year when operated within the specifications given herein.

**ABSOLUTE MAXIMUM RATINGS:** The DC to DC Converters described in this manual are rated for continuous operation when used in an ambient temperature range of 0° to 71°C. Within this range the units will operate in accordance with the specifications listed below, provided they are not subject to stress. The units will function with degraded reliability and life if operated at the extreme ends of the temperature range, at -40° to 0°C, or 71°C to 85°C. Specifications do not apply throughout the entire operating range (-40° to 85°C)

Stresses in excess of the Maximum Ratings can cause permanent damage to the unit. These are absolute stress ratings only. Functional operation of the unit is not implied at these or any other conditions in excess of those in the following Tables.

#### II MODELS:

The following specifications apply to the power supply models listed below:

MODEL	INPUT	OUTPUT
FPD 5-2-60W	36-72 Vdc	5 Vdc 2A
FPD 12-0.8-60W	36-72 Vdc	12 Vdc 0.8A
FPD 15-0.65-60W	36-72 Vdc	15 Vdc 0.65A

#### III INPUT SPECIFICATIONS:

Nominal Input Voltage:	48-60 Vdc
Input Voltage Range:	36-72 Vdc
Input Current: maximum *	625 mA ( $V_I=0$ to 72 Volts, $I_o = I_o, \text{max.}$ )
Efficiency: $V_I=48$ Volts $I_o = I_o, \text{max.}$ ; $T_A=25^\circ\text{C}$ (See Figure 1)	80 percent typical 5 Volts dc Output 83 percent typical 12, 15 Volts dc Output
Switching Frequency:	100 KHz
Circuit Type:	Forward Converter
Input Reflected Ripple Current (Peak-to-Peak, 5 Hz to 20 MHz, 12 $\mu$ H source impedance, $T_A 25^\circ\text{C}$ , see Figure 2)	25 mA Peak-to-Peak, typical
Input Ripple Rejection (120 Hz)	50 dB, typical
Inrush Transient ( $I^2t$ )	0.3 A <sup>2</sup> s typical, 1.0 A <sup>2</sup> s maximum

**\* CAUTION: FPD POWER MODULES ARE NOT INTERNALLY FUSED - INPUT LINE FUSES MUST ALWAYS BE USED.**

#### IV OUTPUT SPECIFICATIONS:

MODEL	FPD 5-2-60W	FPD 12-0.8-60W	FPD 15-0.65-60W
Output Voltage Nominal	5V	12V	15V
Output Current Nominal	2A	0.8A	0.65A
Output Power Maximum	10W	9.6W	9.75W
Ripple <sup>1</sup>	10mV RMS	15mV RMS	15mV RMS
Noise, 5 Hz to 20 MHz	70mV p-p	100mV p-p	100mV p-p
Overcurrent Setting	3.0–5.2A	1.5–2.5A	1.25–2.4
Overvoltage Setting	5.4–7.0V	12.6–16.0V	15.76–19.0V

Source Effect	0.02% Typical — 0.1% Maximum		
Load Effect	0.05% Typical — 0.15% Maximum (10-100% Load)		
Temperature Effect	0.3% Typical — 1.5% Maximum (0-71 Degrees C)		
Combined Effect	0.37% Typical — 1.75% Maximum (Source, Load, Temperature)		
Time Effect	0.1% Typical — 0.1% Maximum (0.5–8 Hours at 25 Degrees C)		
Dynamic Response $\Delta I_o / \Delta t = 1^A / 10\mu s, V_I = 48 \text{ Volts}, T_A = 25^\circ C$ Load change from $I_o = 50\%$ to $75\% I_o, \text{ max.}$ and from $I_o = 50\%$ to $25\% I_o, \text{ max.}$			
Peak Deviation		typ	unit
	FPD 5-2-60W	140	mV
	FPD 12-0.8-60W	200	mV
Settling Time ( $V_o < 10\%$ of peak deviation)	FPD 15-0.65-60W	180	mV
	All Models	3	ms

		MIN.	MAX.	UNIT
Output Voltage (over all operating input voltage, resistive load and temperature conditions)	FPD 5-2-60W	4.84	5.26	Vdc
	FPD 12-0.8-60W	11.4	12.6	Vdc
	FPD 15-0.65-60W	14.25	15.75	Vdc
Output Voltage Set Point ( $V_I = 48 \text{ Volts}, I_o = I_o \text{ max}, T_A = 25^\circ C$ ) from minimum to maximum for all models $\pm 4\%$ , except FPD 5-2-60W $-3\%$	FPD 5-2-60W	4.85	5.2	Vdc
	FPD 12-0.8-60W	11.52	12.48	Vdc
	FPD 15-0.65-60W	14.4	15.6	Vdc
Output Short Circuit Current ( $V_o = 250 \text{ mV}$ )	FPD 5-2-60W	3.5		A
	All Other Models	1.0		A
Output Current Limit Inception $V_o = 4.5V$ $V_o = 10.8$ $V_o = 13.5$	FPD 5-2-60W	3.7	5.5	A
	FPD 12-0.8-60W	1.5	2.5	A
	FPD 15-0.65-60W	1.3	2.4	A
Output Current Limit ( $V_o = 1.0V$ )	FPD 5-2-60W		6.3	A
	FPD 12-0.8-60W		3.0	A
	FPD 15-0.65-60W		3.0	A

**NOTE <sup>1</sup>:** At less than minimum load the DC to DC Converter may exceed its output ripple specifications. Minimum load corresponds to 5% of nominal output current

## V GENERAL SPECIFICATIONS

SPECIFICATIONS		CONDITIONS
Temperature	Operating -40~85 Degrees C Storage - 40 ~ 100 Degrees C	60 ft/min (18.29 m/min) natural convection
Isolation Resistance	10M ohms, Minimum	
Isolation Capacitance	1200 pF typical	
I/O Isolation Voltage	500Vdc maximum	
Dimensions	2.0 (50.8) x 1.6 (40.6) x 0.50 (12.7)	See Mechanical Outline Drawing, Figure 3
Weight	1.60 oz. (45.4 grams) Maximum	
Cover Material	non-conductive material	
Calculated MTBF (80% full Load and Case Temperature = 40°C)	2,500,000 hours	

## VI FEATURE SPECIFICATIONS

		TYP.	MAX.	UNIT
Undervoltage Lockout	Module ON	28	36	V
	Module OFF	24		V
Remote ON/OFF (0 Volts <V <sub>1</sub> < 72 Volts, open collector or equivalent, signal referenced to -V <sub>1</sub> terminal) Logic Low - Module ON; Logic High - Module OFF				
Module Specifications:				
ON/OFF Current	Logic Low		1.0	mA
ON/OFF Voltage	Logic Low		1.2	V
	Logic High		18	V
	(I <sub>ON/OFF</sub> = 0)			
Open Collector Switch Specifications				
Leakage Current During Logic High (V <sub>ON/OFF</sub> = 18V)			50	μA
Output Low Voltage During Logic Low (I <sub>ON/OFF</sub> = 1mA)			1.2	V
Turn On Time (I <sub>o</sub> =80% I <sub>o, max</sub> ; V <sub>o</sub> within ± 1% of V <sub>o, set</sub> )		5		ms
Output Overvoltage Clamp	FPD 5-2-60W	6.0	7.0	V
	FPD 12-0.8-60W	14.0	16.0	V
	FPD 15-0.65-60W	17.0	19.0	V

## VII OUTPUT OVERVOLTAGE CLAMP

The control circuitry for the overvoltage clamp is independent of the FPD DC to DC Converter primary regulation loop. The FPD output voltage is governed by the primary regulation loop. A redundant output voltage control is provided by the overvoltage clamp circuitry, thereby reducing the possibility of output overvoltage. This redundancy is realized by having the set point of the overvoltage clamp designed to be higher than the set point of the primary loop.

## VIII CURRENT LIMIT

The FPD DC to DC Converter is protected against output overload by internal current limiting. This mode of operation can be maintained for an unlimited time duration. At the very point of current limit inception the DC to DC converter shifts from a voltage control to a current control mode. In a severe fault situation (where the output voltage is pulled very low) the current limit circuit can be either foldback or taylor in characteristic (output current

decrease or increase). However, the FPD unit operates normally once the output current returns within its specified range.

#### IX REMOTE ON/OFF

The DC to DC Converter can be remotely controlled via a switch (that the user must supply) across the ON/OFF terminal and the  $-V_I$  terminal ( $V_{ON/OFF}$ ). At logic low  $V_{ON/OFF}=0$  to 1.2 Volts, the unit is ON; and the maximum  $I_{ON/OFF}$  (when the module is ON) is 1 mA. The switch should be able to sink 1 mA when it is at a logic low voltage. At logic high the maximum  $V_{ON/OFF}$  of the FPD unit is 18 Volts. The maximum allowable leakage current of the switch (at logic high) is then  $50\mu A$ .

A jumper across the ON/OFF terminal and the  $-V_I$  terminal can be used to override the Remote ON/OFF (see Figure 4). Either a user-supplied switch or the override jumper should be wired into the circuit via individual PWB current paths not common to the  $-V_I$  current path. Connect the switch or jumper wire at the FPD terminals, across the common connection point and the Remote ON/OFF point. This connection will prevent noise from falsely triggering the Remote ON/OFF.

#### X INPUT FILTERING

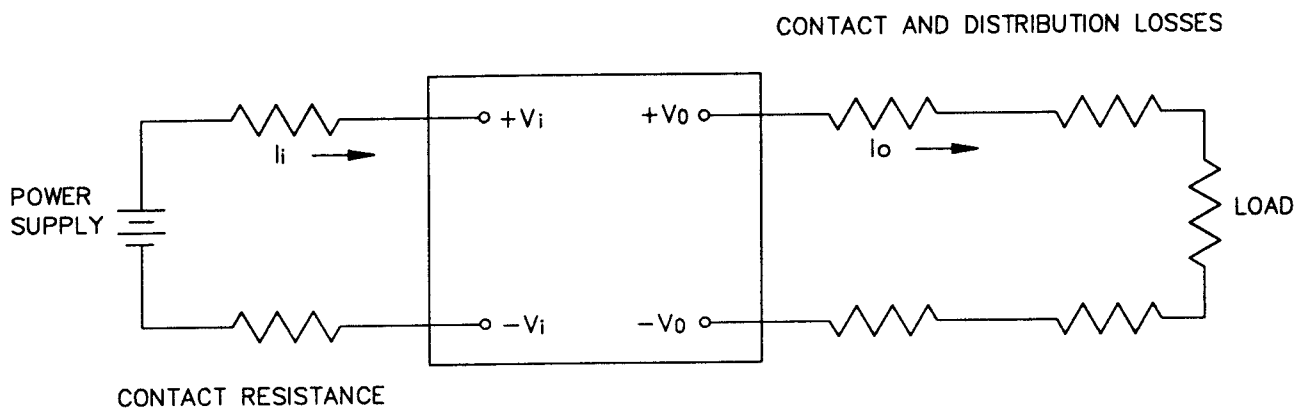
An aluminum electrolytic capacitor is used at the input terminals for filtering the FPD unit. Consequently the ripple increases as the temperature decreases. For example at  $0^\circ C$  there is twice as much ripple than at  $25^\circ C$ , at  $-40^\circ C$  there is eight times as much ripple than at  $25^\circ C$ . DC to DC Converter operation down to  $-40^\circ C$  is possible without additional filtering. If required, an external filter capacitor across the input terminals (an impedance of 0.3 ohms at 100 MHz over the desired temperature range is recommended) should limit the input ripple current to within the typical levels given in the input specifications.

#### XI OUTPUT VOLTAGE REVERSAL

**CAUTION:** Do not apply a reverse polarity voltage across the FPD output terminals. Such an application will forward bias an internal diode of the Power Module and damage the FPD unit.

#### XII ISOLATION

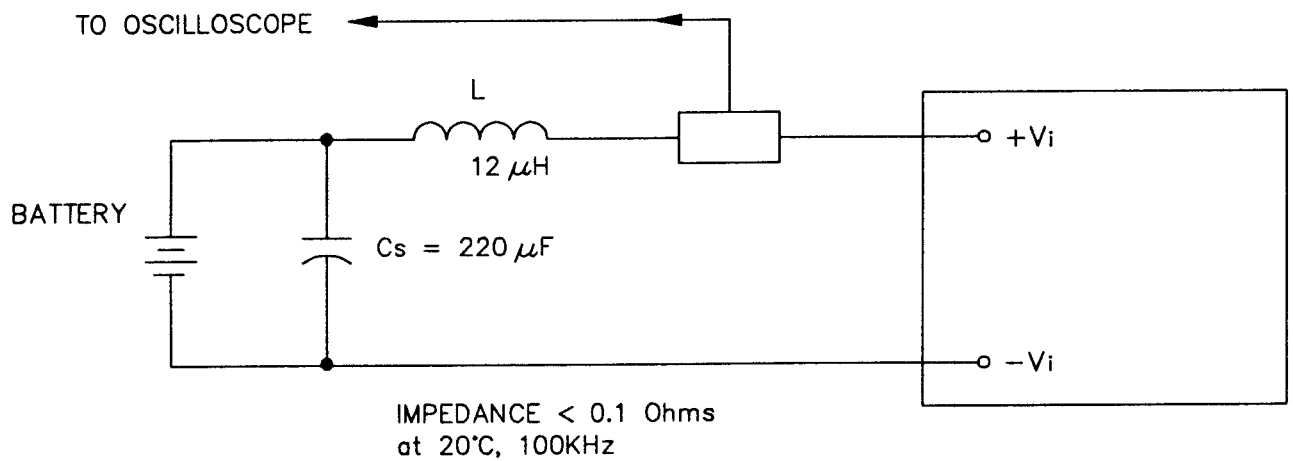
The FPD outputs are fully isolated from the inputs. FPD DC to DC Converters are encapsulated in nonconductive cases that mount on PC boards. The modules are rated to full load at  $85^\circ C$  in a natural convection environment (without a heat sink or external filter). They also comply with FCC Class A EMI requirements.



**FIGURE 1 TEST SET UP FOR OUTPUT VOLTAGE AND EFFICIENCY MEASUREMENTS FOR THE SINGLE OUTPUT FPD DC TO DC CONVERTER. WHEN PLACING THE POWER MODULE INTO A PRINTED CIRCUIT BOARD SOCKET, USE KELVIN CONNECTIONS AT THE POWER MODULE INPUT AND OUTPUT TERMINALS TO AVOID MEASUREMENT ERRORS DUE TO SOCKET CONTACT RESISTANCE.**

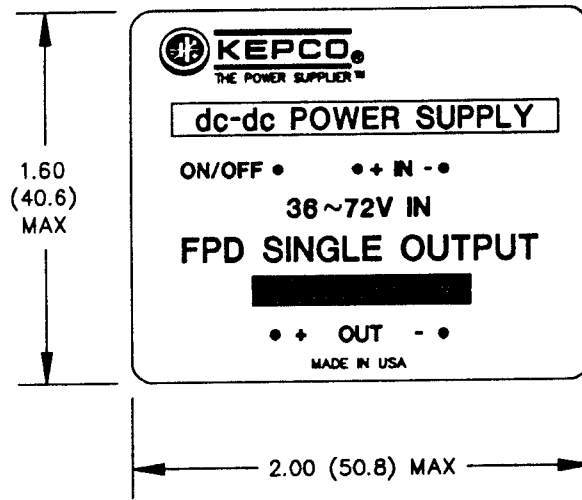
**NOTE: THE EQUATION FOR POWER MODULE EFFICIENCY IS**

$$\eta = \frac{[+V_0 \ -(-V_0)] I_0}{[+V_1 \ -(-V_1)] I_1}$$

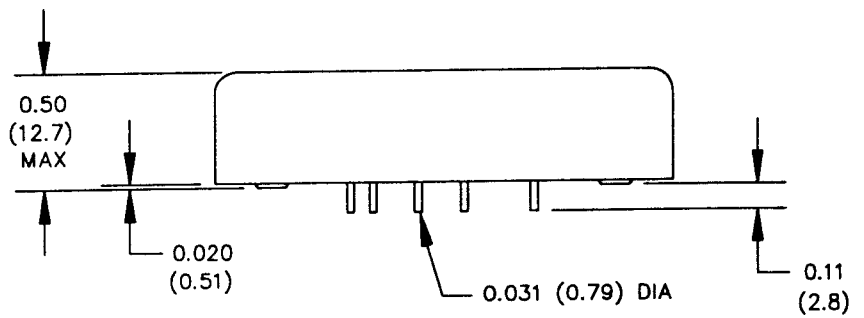


**FIGURE 2 TEST SET UP FOR INPUT REFLECTED RIPPLE FOR THE SINGLE OUTPUT FPD DC TO DC CONVERTER. THE INPUT REFLECTED RIPPLE IS MEASURED WITH A SIMULATED SOURCE IMPEDANCE OF  $12 \mu\text{H}$ . THE CAPACITOR  $C_s$ , OFFSETS POSSIBLE BATTERY IMPEDANCE. CURRENT IS MEASURED AT THE INPUT OF THE POWER MODULE**

TOP VIEW



SIDE VIEW



BOTTOM VIEW

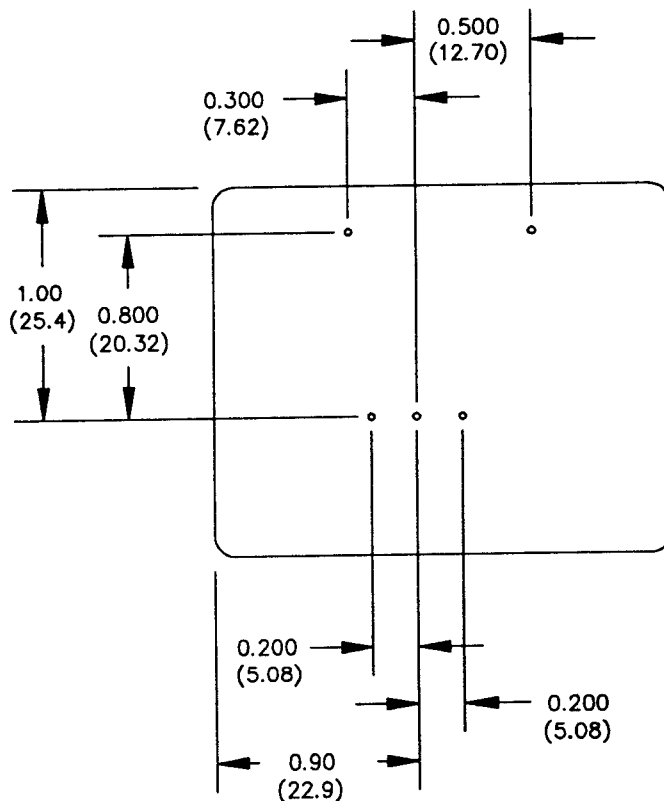
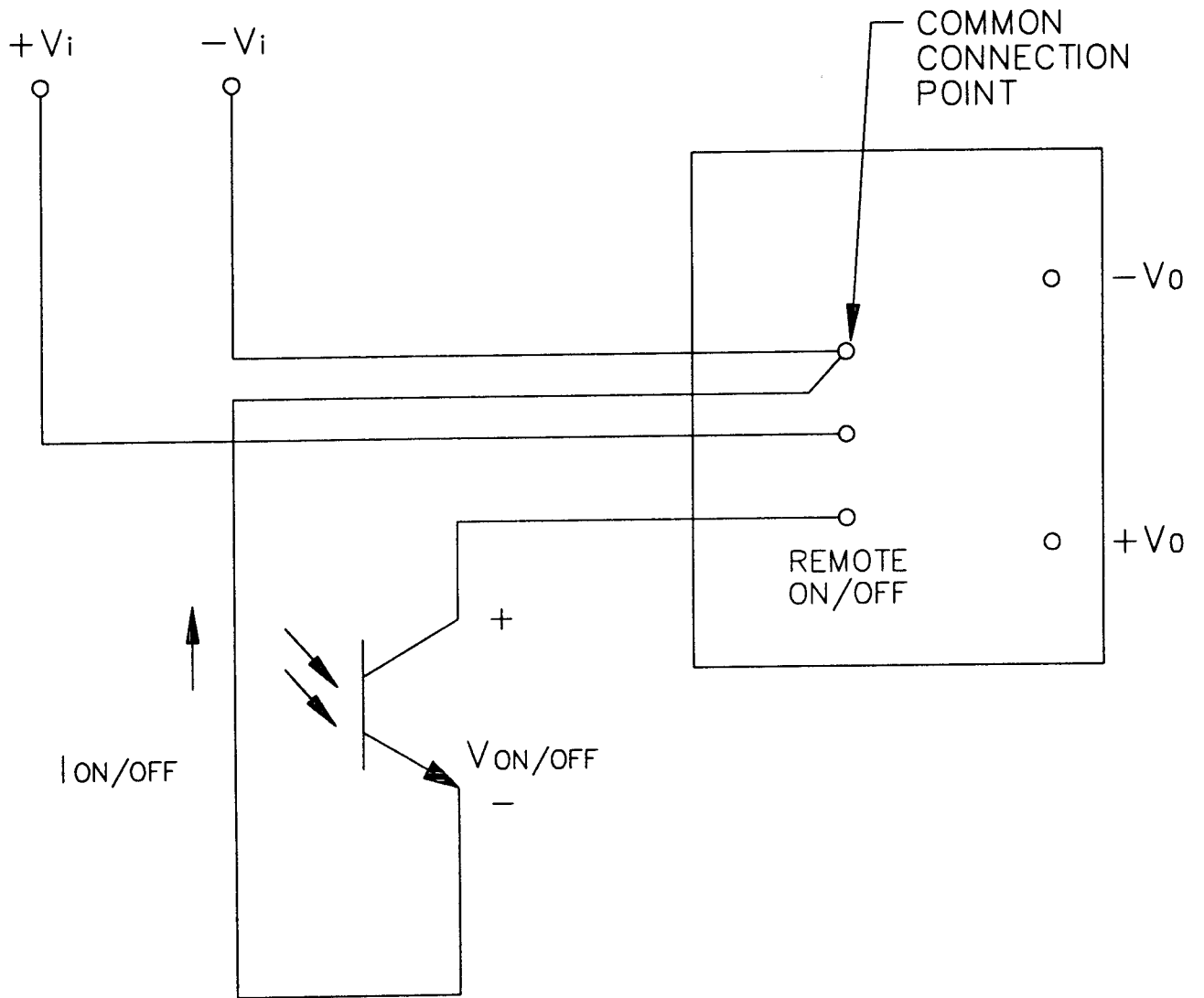


FIGURE 3 MECHANICAL OUTLINE DRAWING OF THE SINGLE OUTPUT FPD DC TO DC CONVERTER





**FIGURE 4** REMOTE ON/OFF WIRING CONFIGURATION FOR THE SINGLE OUTPUT FPD DC TO DC CONVERTER